



DUMPER 1000-1200 NT/SN



DUMPER

1000-1200 NT/SN

SCARICO IDRAULICO FRONTALE
 DESCHARGEMENT HYDRAULIQUE FRONTAL
 HYDRAULIC FRONTAL TIPPING
 DESCARGA HIDRAULICA FRONTAL

SPECIFICATIONS / CARATTERISTICHE TECNICHE DONNEES TECHNIQUES / CARACTERISTICAS TECNICAS

	1000 NT/SN		1200 NT/SN	
SKIP CAPACITIES CAPACITA' DELLA BENNA CAPACITE' DE LA BENNE CAPACIDAD DE LA TOLVA	1.000 ltr struck / a raso à ras / nivel de agua	1.200 ltr heaped / a colmo comblee / colmada	1.200 ltr struck / a raso à ras / nivel de agua	1.500 ltr heaped / a colmo comblee / colmada
MAX PAYLOAD PORTATA PORTEE CARGA UTIL	2.500 Kg		3.000 Kg	
UNLOADED WEIGHT PESO A VUOTO POIDS À VIDE PESO EN VACIO	1.390 Kg		1.500 Kg	
DIESEL ENGINE LOMBARDINI MOTORE DIESEL LOMBARDINI MOTEUR DIESEL LOMBARDINI MOTOR DIESEL LOMBARDINI	9LD 625.2 / 2G40 HATZ electric start / HATZ avv. elettrico HATZ démarrage électrique / HATZ arranque eléctrico			
POWER POTENZA PUISSANCE POTENCIA MOTOR	HP 28,5 / HP 23		HP 28,5 / HP 23	
NR. CYLINDERS NR. CILINDRI NR. CYLINDRES NR. CILINDROS	2		2	
TRANSMISSION TRASMISSIONE TRANSMISSION TRANSMISION	✓		✓	
FORWARD / REVERSE GEARS MARCE AVANTI / INDIETRO VITESSE AV / AR VELOCIDADES ADELANTE / ATRAS	4 / 4		4 / 4	
SINGLE DRY PLATE CLUTCH FRIZIONE MONODISCO A SECCO EMBRAYAGE MONODISQUE À SEC EMBRAGUE MONODISCO EN SECO	✓		✓	
MAX SPEED VELOCITÀ MAX VITESSE MAX VELOCIDAD MAX	25 Km/h		25 Km/h	
BRAKES FRENI FREINS FRENOS	✓		✓	
WHEELS DRIVE RUOTE MOTRICI ROUES MOTRICES RUEDAS MOTRICES	4		4	
TYRES FRONT / REAR PNEUMATICI AVANTI / DIETRO PNEUS AVANT / DERRIERE NEUMÁTICOS DELANTE / ATRAS	7,50 - 16		10,0 / 75 - 15,3	

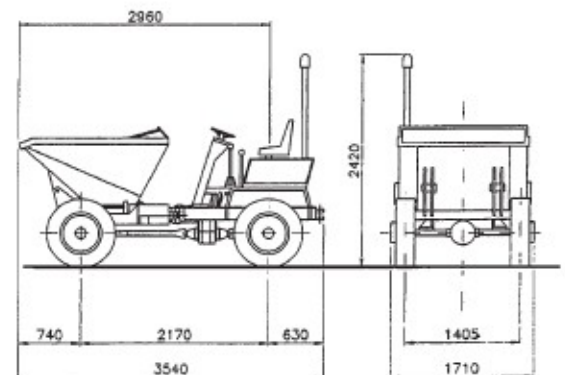

New dashboard
 Nuovo cruscotto
 Nouveau tableau de bord
 Nuevo tablero de instrumentos

OPTIONAL:

Road lighting
 Impianto fari
 Équipement d'éclairage pour circulation routière
 Equipo completo de luces para la carretera

Protective roof
 Tettino di protezione
 Toit de protection
 Techo protector del conductor